



Free choice of Modem Specification

Description of the prerequisites for a VDSL2 modem intended to establish a connection with the Proximus VDSL2 network.



Table of contents

Table of contents	2
Abbreviations and definitions	3
1 Summary.....	4
2 Disclaimers	4
3 VDSL2 specifications	5
3.1 Characterization of requirements : terminology used	5
3.2 System reference model.....	6
3.3 CPE VDSL2 modem requirements	7
3.3.1 The proximus VDSL2 network and the main interoperability combinations with a freely chosen end user CPE.....	7
3.3.2 Generic requirements for operation with all line cards	7
3.3.3 Requirements when operating with NVLT-D non vectored VDSL2.....	9
3.3.4 Requirements when operating with NDLT-G non vectored VDSL2	11
3.3.5 Requirements when operating with NDLT-G vectored VDSL2	12
3.3.6 Requirements when operating with RDLT-G vectored VDSL2	15
4 Definition of harm to the network.....	15
5 Proximus, CPE vendor and end user Roles and Responsibilities	16
5.1 Proximus Roles and Responsibilities.....	16
5.2 CPE vendor Roles and Responsibilities	17
5.3 End user Roles and Responsibilities	17

Table of figures

Figure 1 : system referece model.....	6
---------------------------------------	---



Abbreviations and definitions

CPE	Customer (in the sense of “end user”) Premises Equipment that contains a VDSL2 modem
DSLAM	DSL Subscriber Line Access Multiplexer (the VDSL2 network equipment)
FTTCab	Fiber To The Cabinet
FTTN	Fiber To The Node
HW	Hardware
NT	Network Termination
NTP	Network Termination Point
SW	Software
VDSL2 modem	The physical implementation of the VTU-R functionality (see section 3.2 and Figure 1) that resides in the CPE



1 Summary

This document is provided within the framework of the BIPT Decision of 26 September 2023 regarding the identification of the network termination point for broadband services. The information contained herein pertains to Proximus' network specifications and is intended exclusively for end users.

The specifications contained in this document aim to provide the necessary VDSL2 physical layer requirements for a freely chosen end user CPE :

- To be interoperable against the Proximus VDSL2 network with reasonable performance
- To not create harm to the network as defined in section 4

The document refers in first instance to state-of-the-art standards and details additional requirements to ensure the VDSL2 modem operation on the Proximus network.

The document also provides information on the Proximus, CPE vendor and end user technical Roles and Responsibilities and Proximus' right to intervene to ensure the correct network operation for all end users.

2 Disclaimers

- The information presented in this document is based on the current state of information and network specifications, subject to change. It is recommended to regularly check for updates and revisions.
- It is impossible to write "exhaustive" specifications for a particular deployment context in order to :
 - warrant a minimum quality with a very high guarantee
 - warrant no harm to the network with a very high guarantee.

This is the prime reason why CPE equipment should ideally be validated for a particular deployment context with lab tests (e.g. Proximus certification process), field trials and pilots. Hence Proximus cannot assume any responsibility if a given CPE :

- Does not meet the VDSL2 performance expectations of the end user, even in case the CPE vendor of said CPE claims that its CPE is compliant to these specifications*
- Creates harm to the network, even in case the CPE vendor of said CPE claims that its CPE is compliant to these specifications*

*this being said, obviously a correct CPE vendor statement of compliance significantly increases the probability of reasonable performance and no harm to the network .

- This interface specification may be changed at any time and may break backward compatibility with previous versions.
- The publication of a new version of this specification renders all prior versions null and void, in accordance with any applicable delay periods.
- The specifications outlined in this document are provided on an "as-is" basis. While every effort has been made to ensure accuracy, Proximus shall not be liable for any direct, indirect, incidental, consequential, or special damages arising out of the use of this information.
- End users utilizing this document are encouraged to consult Proximus for any additional clarifications or updates to ensure optimal compatibility with the Proximus residential network.



3 VDSL2 specifications

3.1 Characterization of requirements : terminology used

According to the conventions also used into the Broadband Forum Technical Recommendations, the words SHALL, SHALL NOT, SHOULD, SHOULD NOT and MAY have to be understood as follows:

SHALL	This word, or the term "REQUIRED", means that the definition is an absolute requirement of the specification.
SHALL NOT	This phrase means that the definition is an absolute prohibition of the specification.
SHOULD	This word, or the adjective "RECOMMENDED", means that there may exist valid reasons in particular circumstances to ignore this item, but the full implications must be understood and carefully weighed before choosing a different course.
SHOULD NOT	This phrase, or the phrase "NOT RECOMMENDED" means that there may exist valid reasons in particular circumstances when the particular behavior is acceptable or even useful, but the full implications should be understood and the case carefully weighed before implementing any behavior described with this label.
MAY	This word, or the adjective "OPTIONAL", means that this item is one of an allowed set of alternatives. An implementation that does not include this option MUST be prepared to inter-operate with another implementation that does include the option.

3.2 System reference model

Figure 1 (equivalent to Figure 5-4/G.993.2) depicts the reference model used for VDSL2. At the network side the VDSL2 transceiver unit (VTU-O) resides at the VDSL2 line cards contained by the access node and can be located as well in the central office as in a remote location in a FTTCab or FTTFNode deployment scenario. From the line card existing unscreened twisted metallic access wire-pairs are used to convey the broadband (VDSL2) and narrowband (PSTN) signals to and from the customer's premises.

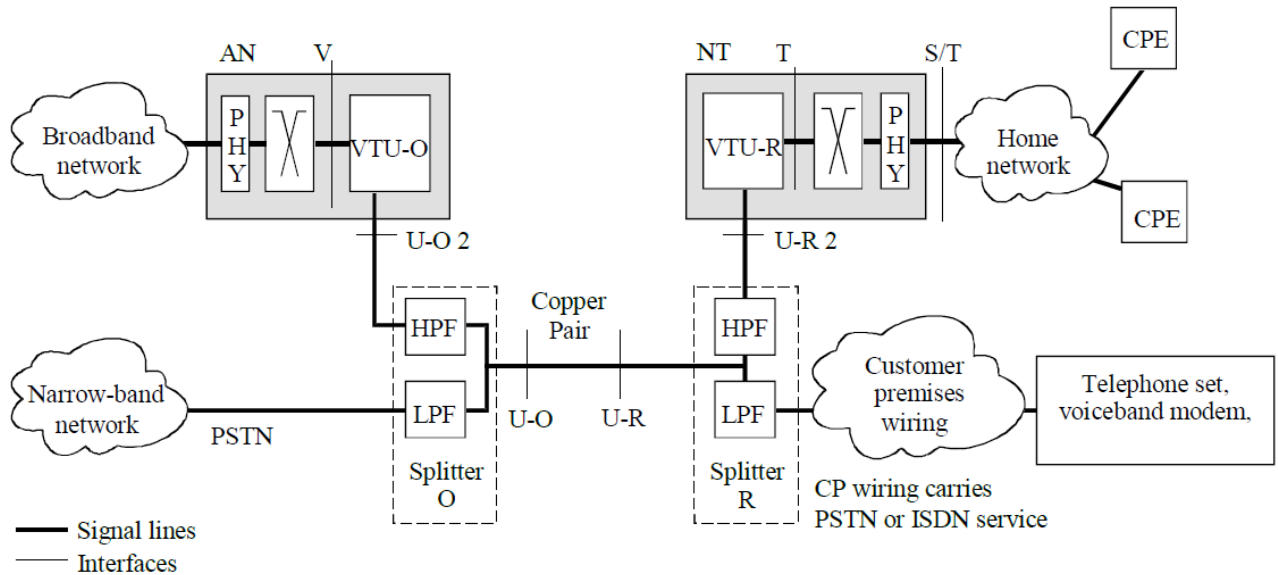

Figure 1 : system referece model

At the CPE side the VDSL2 NT (Network Termination) contains the VDSL2 modem functionality (VTU-R) as well as the high pass filter functionality (HPF). In terms of VDSL2 signals the U-R and U-R2 interfaces are thus equivalent (see also note 3 to Figure 5-4/G.993.2). When PSTN and VDSL2 are transmitted onto the same physical public network copper line, a master (centralised) low pass filter splitter (LPF) is used to isolate narrowband (PSTN) and broadband VDSL2 transmission signals on the customer premises wiring. The master splitter is connected to the NTP (Network Termination Point) which is described in the latest version of the document "PXS_VDSLNTpspecs".



3.3 CPE VDSL2 modem requirements

3.3.1 The proximus VDSL2 network and the main interoperability combinations with a freely chosen end user CPE

The main possible interoperability counterparts for a freely chosen CPE that may be encountered in the Proximus Network are the following Nokia line cards.

Line card	Main DSL standards	Minimum Start Frequency
NVLT-D non vectored	G.993.2 Annex B	f0L >= 120kHz
NDLT-G non vectored	G.993.2 Annex B	f0L >= 25kHz
NDLT-G vectored	G.993.2 Annex B G.993.5 (Vectoring) G.998.4 (G.INP)	f0L >= 25kHz
RDLT-G vectored	G.993.2 Annex B G.993.5 (Vectoring) G.998.4 (G.INP)	f0L >= 25kHz

Table 1: Nokia line cards in the Proximus VDSL2 network

The VDSL2 CPE shall be interoperable with and interwork with all these interoperability counterparts per the requirements in the following sections 3.3.2, 3.3.3, 3.3.4, 3.3.5 and 3.3.6.

3.3.2 Generic requirements for operation with all line cards

3.3.2.1 RJ11 DSL interface

R-1 The physical DSL interface to connect the CPE to the Proximus copper NTP (please refer to the latest version of the document "PXS_VDSLNTSpecs") shall be a female RJ11 connector.

3.3.2.2 CPE DSL inventory information coding

R-2 The xTU-R G.994.1 vendor identifier, the xTU-R system vendor identifier, the xTU-R version number and the xTU-R serial number shall be coded as specified in G.997.1 (02/2019).

Note : an allowed exception to this requirement is that the xTU-R version number does not contain the <xTU-R model>.

3.3.2.3 Management of G.hs handshake tonesets and interoperability with the heterogeneous Proximus VDSL2 network

R-3 The CPE shall not transmit the V43 handshake toneset when interworking with any other VDSL2 capable line card than NVLT-D (e.g. NDLT-G or RDLT-G) in order to :

- avoid harm to the network because of disturbances in the upstream direction in case of e.g. UPBO relaxation enabled by upstream vectoring which is deployed by Proximus



- avoid successful G.hs completion over a crosstalk channel which leads to a degradation of the vectoring initialisation performance
- avoid successful initialisation over a crosstalk channel

R-4 The CPE should transmit the V43 handshake toneset when interworking with the NVLT-D line card to assure best interoperability performance against NVLT-D.

R-5 In order to achieve both preceding requirements R-3 and R-4, the CPE shall :

- either never transmit the G.hs V43 toneset, but then the possible performance penalties when interworking with the NVLT-D line card need to be acceptable to the end user
- or implement the necessary G.hs toneset management logic that may be custom.

R-6 The CPE shall be interoperable with all VDSL2 line cards in the Proximus network as defined in Table 1. Since NVLT-D on the one hand and NDLT-G and RDLT-G on the other hand support a different minimum start frequency f_{OL} and support and may use different handshake tone sets during initialization, the CPE should implement the necessary mechanisms to cope with this without prior knowledge onto which line card the CPE will be connected. Note : the probability that a VDSL2 end user is connected to the NVLT-D line card in the Proximus network is around 6%

3.3.2.4 Common mode noise suppression

R-7 The CPE shall support common mode noise suppression in order to be sufficiently robust against common mode noise and in order to not cause harm to the network caused by common mode noise originating in the end user premises (caused by e.g. a bad power supply) that is converted into differential noise to neighbouring lines in the public network. To meet this requirement the CPE shall be compliant to G.995.2.

3.3.2.5 Dying gasp

R-8 The proposed CPE should support dying gasp as well as the associated far-end lpr primitive (e.g. G.993.2 (2015) 11.3.3.2 for VDSL2) and contain a capacitor in order to enable it. Upon detection of the near-end loss of power by the xTU-R, the CPE should send the lpr indicator bit at least 3 consecutive times prior to transitioning to link state L3.

3.3.2.6 Avoidance of initialisation over any crosstalk channel in the Proximus network

R-9 In addition to compliance to R-5 the CPE should implement the necessary mechanisms to avoid initialization over any crosstalk channel in the Proximus network.

3.3.2.7 Avoidance of performance degradation due to out of band FEXT caused by 35 MHz VDSL2 neighbouring lines

R-10 The CPE should support the necessary receiver functionality to avoid that at a future point in time 35 MHz VDSL2 signals on neighbouring lines would significantly negatively impact the performance of the line in 17a or 8x VDSL2 profile. 35 MHz FEXT out of band noise above 17,6 MHz could negatively impact the performance of the line in 17a or 8x VDSL2 profile through aliasing depending on amongst others the receiver filter implementation.



3.3.3 Requirements when operating with NVLT-D non vectored VDSL2

3.3.3.1 Compliance to G.993.2

3.3.3.1.1 Generic requirements

R-11 The CPE shall be compliant to G.993.2 (2006-02).

R-12 The CPE shall be compliant to G.993.2 corrigendum 1.

R-13 The CPE shall be compliant to G.993.2 amendment 1.

R-14 The CPE shall be compliant to G.993.2 amendment 1 corrigendum 1.

R-15 The CPE shall be compliant to G.993.2 corrigendum 2.

R-16 The CPE should be compliant to G.993.2 amendment 2.

R-17 The CPE shall be compliant to G.993.2 amendment 3.

R-18 The CPE shall be compliant to G.993.2 amendment 4.

R-19 The CPE shall be compliant to G.993.2 corrigendum 3.

R-20 The CPE shall be compliant to G.993.2 amendment 5.

R-21 The CPE shall be compliant to G.993.2 amendment 6 revision of CI policy.

R-22 The CPE shall be compliant to G.993.2 corrigendum 4.

R-23 The CPE shall be compliant to G.993.2 amendment 7.

R-24 The CPE shall support VDSL2 profiles 8a, 8b, 8c, 8d,12a, 12b, 17a.

R-25 The CPE shall support UO for VDSL2 17a profile.

R-26 The CPE shall be compliant to G.993.2 Annex B.

R-27 The CPE shall be compliant to G.993.2 Annex K.3 and G.993.2 Annex N (EFM 802.ah 64/65).



- R-28** The CPE shall support UPBO ELE-M0 per G.993.2 (01/2015).
- R-29** The CPE shall support UPBO ELE-M1 AELE-MODE 3 per G.993.2 (01/2015).
- R-30** Bit swapping: the CPE shall support bit swapping down to 0 bit loading and upwards from 0 bit loading up to non-zero bit loading in the downstream and upstream direction.
- R-31** The CPE shall support all MIB-controlled DS PSD masks (up to 32 breakpoints) and US PSD masks (up to 16 breakpoints) meeting the constraints and requirements as described in G.993.2 section 7.2.1.1.
- R-32** Within the constraints of the mandatory MBDC for profile 17a the CPE shall support any mix of downstream net data rates and upstream net data rates with:
- downstream net data rates up to 95 Mbps
 - upstream net data rates up to 50 Mbps
- R-33** Interleaver: the downstream and upstream partition of the aggregate interleaver delay in octets shall be dynamic.
- R-34** By default the CPE shall implement $C|policy_n = 2$.
- R-35** The CPE should support transmitter referred virtual noise ($SNRM_MODE = 2$).
- R-36** The CPE should support impulse noise monitor sensor.

3.3.3.1.2 VDSL2 8x band plans & PSD mask

- R-37** The CPE shall support band plan 998 with $f_{OL} = 120$ kHz, $f_{OH} = 276$ kHz, $f_1 = 276$ kHz and limit mask PSD B8-6.
- R-38** The CPE shall support band plan 998 with $f_{OL} = N/A$, $f_{OH} = N/A$, $f_1 = 138$ kHz and limit mask PSD B8-7.

3.3.3.1.3 VDSL2 17a band plans & PSD masks

- R-39** The CPE shall support band plan 998ADE17 with $f_{OL} = 120$ kHz, $f_{OH} = 276$ kHz, $f_1 = 276$ kHz and limit mask PSD B8-12.
- R-40** The CPE shall support band plan 998ADE17 with $f_{OL} = N/A$, $f_{OH} = N/A$, $f_1 = 276$ kHz and limit mask PSD B8-10.

3.3.3.2 Compliance to G.997.1

- R-41** The CPE shall be compliant with G.997.1 (04/09).
- R-42** The CPE shall be compliant to G.997.1 Corrigendum 1 (11/2009).
- R-43** The CPE shall be compliant to G.997.1 Amendment 1.
- R-44** The CPE shall be compliant to G.997.1 Amendment 2.



3.3.3.3 Compliance to G.994.1

R-45 The CPE shall be compliant to G.994.1 (02/2007).

R-46 The CPE shall be compliant to G.994.1 Amendment 1 (11/2007).

R-47 The CPE shall be compliant to G.994.1 Amendment 6.

R-48 The CPE shall be compliant to G.994.1 Amendment 7.

3.3.3.4 Interoperability requirements

All the below Broadband Forum TR related requirements in this section 3.3.3.4 shall be applicable against Nokia 7302 ISAM with NANT-A and with NVLT-D line card and NVSU-B splitter card with ISAM SW version R6.2.04h..

R-49 The CPE shall be compliant to TR-114 Issue 1 main body and Annex B for all BB test cases (B.5, B.6, B.7, B.9, B.17 and B.18 and BB test cases in B.11, B.12 and B.13). Minor fails may be acceptable if these do not create harm to the network as defined in section 4.

R-50 The CPE shall be compliant to TR-115 Issue 1. Minor fails may be acceptable if these do not create harm to the network as defined in section 4.

R-51 The CPE shall be compliant to TR-138 (including amendment 1). Minor fails may be acceptable if these do not create harm to the network as defined in section 4.

R-52 In both downstream and upstream direction the BER shall be significantly lower than $10E-10$ in interleaved mode at 6 dB noise margin when measured with an impulse noise free set-up. The BER shall be estimated according to TR-114 Issue 1 section 8.2 Table 23.

R-53 In both downstream and upstream direction the BER should be significantly lower than $10E-10$ in fast mode at 6 dB noise margin when measured with an impulse noise free set-up. The BER shall be estimated according to TR-114 Issue 1 section 8.2 Table 23.

3.3.4 Requirements when operating with NDLT-G non vectored VDSL2

The same requirements as specified in section 3.3.5 shall be met, except for :

- The G.993.5 and G.998.4 requirements do not need to be met since these are not applicable to the NDLT-G - VDSL2 non vectored interoperability combination.
- The interoperability counterpart DSLAM consists of Nokia 7302 ISAM with NANT-A and with NDLT-G line card and NVSP-B splitter card instead of Nokia 7356 SB-REM with NDLT-G line card, NVSP-B splitter card and NRCD-C vectoring controller card.



3.3.5 Requirements when operating with NDLT-G vectored VDSL2

3.3.5.1 Compliance to G.993.2

3.3.5.1.1 Generic requirements

All requirements in this section 3.3.5.1.1 shall be applicable for all VDSL2 profiles 8x and 17a (if relevant for a given VDSL2 profile) unless specifically stated otherwise

R-54 The CPE shall be compliant to G.993.2 (02-2019).

R-55 The CPE shall support VDSL2 profiles 8a, 8b, 8c, 8d,12a, 12b, 17a.

R-56 The CPE shall support U0 for VDSL2 17a profile.

R-57 The CPE shall be compliant to G.993.2 Annex B.

R-58 The CPE shall be compliant to G.993.2 Annex Q for 17a.

R-59 The CPE shall support UPBO ELE-M1 AELE-MODE 3 per G.993.2 (01/2015).

R-60 Bit swapping: the CPE shall support bit swapping down to 0 bit loading and upwards from 0 bit loading up to non-zero bit loading in the downstream and upstream direction.

R-61 The CPE shall support G.993.2 Annex L.3 and G.993.2 Annex Y (EFM 802.ah 64/65).

R-62 The CPE shall support all MIB-controlled DS PSD masks (up to 32 breakpoints) and US PSD masks (up to 16 breakpoints) meeting the constraints and requirements as described in G.993.2 section 7.2.1.1.

R-63 Within the constraints of the mandatory MBDC for profile 17a the CPE shall support any mix of downstream net data rates and upstream net data rates with:

- downstream net data rates up to 150 Mbps
- upstream net data rates up to 50 Mbps

R-64 Interleaver: the downstream and upstream partition of the aggregate interleaver delay in octets shall be dynamic.

R-65 By default the CPE shall implement $Clpolicy_n = 2$.

R-66 The CPE should support transmitter referred virtual noise (SNRM_MODE = 2).

R-67 The CPE should support impulse noise monitor sensor.

R-68 The CPE shall support SRA in downstream and upstream direction with dynamic interleaver depth change such that after an SRA step Min INP and Max Delay configured boundaries are not violated.

R-69 The CPE should support SOS in downstream and upstream direction.



3.3.5.1.2 VDSL2 8x band plans & PSD mask

- R-70** The CPE shall support band plan 998 with $f_{OL} = 25$ kHz , $f_{OH} = 138$ kHz , $f_1 = 138$ kHz and limit mask PSD B8-4.
- R-71** The CPE shall support band plan 998 with $f_{OL} = 25$ kHz , $f_{OH} = 276$ kHz , $f_1 = 276$ and limit mask PSD B8-5.
- R-72** The CPE shall support band plan 998 with $f_{OL} = 120$ kHz, $f_{OH} = 276$ kHz , $f_1 = 276$ kHz and limit mask PSD B8-6.
- R-73** The CPE shall support band plan 998 with $f_{OL} = N/A$, $f_{OH} = N/A$, $f_1 = 138$ kHz and limit mask PSD B8-7.

3.3.5.1.3 VDSL2 17a band plans & PSD masks

- R-74** The CPE shall support band plan 998ADE17 with $f_{OL} = 25$ kHz, $f_{OH} = 138$ kHz, $f_1 = 138$ kHz and limit mask PSD B8-11.
- R-75** The CPE shall support band plan 998ADE17 with $f_{OL} = 120$ kHz, $f_{OH} = 276$ kHz, $f_1 = 276$ kHz and limit mask PSD B8-12.
- R-76** The CPE shall support band plan 998ADE17 with $f_{OL} = 25$ kHz, $f_{OH} = 276$ kHz, $f_1 = 276$ kHz and limit mask PSD B8-17.
- R-77** The CPE shall support band plan 998ADE17 with $f_{OL} = N/A$, $f_{OH} = N/A$, $f_1 = 276$ kHz and limit mask PSD B8-10.

3.3.5.2 Compliance to G.993.5

- R-78** The CPE shall be compliant with G.993.5 (2019-02).
- R-79** The CPE shall support the Layer 2 backchannel.
- R-80** The CPE shall support showtime updating of the US pilot sequence as described in G.993.5 section 8.2.
- R-81** The CPE should support G.993.5 Annex A use of extended error clipping threshold. .
- R-82** The CPE should support downstream FDPS (frequency dependent pilot sequences).
- R-83** When operating in vectored VDSL2 mode the CPE shall implement mechanisms to :
- detect disorderly leaving events (events where LO showtime is exited without the VCE being able to take measures enabled by orderly leaving) with a few ms detection precision
 - upon detection of such events take appropriate action to mitigate the possible detrimental effect onto neighbouring lines in the same vectoring group, e.g. by proactively shutting down the CPE upstream transmit signal upon :



- detection of VTU-R power down provided that the CPE HW foresees sufficient energy autonomy (e.g. when dying gasp is supported) for subsequent CPE upstream transmit signal shutdown after the the lpr indicator bit has been sent at least 3 consecutive times.
- detection of persistent downstream signal loss

R-84 The CPE power-down button should trigger a software controlled power down procedure, instigating an “Orderly Shutdown” with L3 request by the VTU-R (G.993.5 section 8.3.1).

R-85 Any loss of AC mains on the external AC/DC converter and any loss of DC mains at the CPE side should trigger a software controlled power down procedure, instigating an “Orderly Shutdown” with L3 request by the VTU-R (G.993.5 section 8.3.1).

R-86 The CPE shall support Orderly Shutdown as described in G.993.5 section 9.1. This implies support for the G.vector modified L3 request.

R-87 The CPE shall support “L3 Request by VTU-R” as described in G.993.5 section 8.3.1.

R-88 The CPE shall support “L3 Request by VTU-O” as described in G.993.5 section 8.3.2.

R-89 Any SW triggered CPE shut-down or reboot shall be managed by the CPE as an orderly leaving event.

R-90 The CPE should implement measures to reduce the probability for pilot sequence probe tone demapping errors from occurring (see also ITU-T contribution 2015-03-10-Q4-O21R2.docx section 4.3).

3.3.5.3 Compliance to G.998.4

R-91 The CPE shall be compliant with G.998.4 (11/2018) in downstream and upstream direction in conjunction to VDSL2.

3.3.5.4 Compliance to G.997.1

R-92 The CPE shall be compliant with G.997.1 (11/2016).

R-93 The CPE shall be compliant with G.997.1 (2016) Amendment 1 (12-2017).

R-94 The CPE shall be compliant with G.997.1 (2016) Corrigendum 1 (03-2018).

R-95 The CPE shall be compliant with G.997.1 (2016) Amendment 2 (05-2018).

3.3.5.5 Compliance to G.994.1

R-96 The CPE shall be compliant with G.994.1 (11/2018).

3.3.5.6 Interoperability requirements

All the below Broadband Forum TR related requirements in this section 3.3.5.6 shall be applicable for the CPE against Nokia 7356 SB-REM with NDLT-G line card, NVSP-B splitter card and NRCD-C vectoring controller card with ISAM SW version R6.2.04h. Note : the 7356 SB-REM is aggregated by Nokia 7330 ISAM Host with NANT-A.



R-97 The CPE shall be compliant in G.993.5 mode to TR-114 Issue 3 main body and Annex B for all BB test cases (B.5, B.6, B.7 and B.9 and BB test cases in B.10, B.11 and B.12).

R-98 The CPE shall be compliant in G.993.5 mode to TR-115 Issue 3.

R-99 The CPE shall be compliant in G.993.5 mode to TR-138 (including amendment 1).

R-100 In both downstream and upstream direction the BER shall be significantly lower than $10E-10$ in interleaved mode at 6 dB noise margin when measured with an impulse noise free set-up. The BER shall be estimated according to TR-114 Issue 3 section 8.2 Table 24.

R-101 In both downstream and upstream direction the BER should be significantly lower than $10E-10$ in fast mode at 6 dB noise margin when measured with an impulse noise free set-up. The BER shall be estimated according to TR-114 issue 3 section 8.2 Table 24.

3.3.6 Requirements when operating with RDLT-G vectored VDSL2

The same requirements as specified in section 3.3.5 shall be met, except for :

- The interoperability counterpart DSLAM consists of Nokia 7363 MX6 with RANT-C NT and with RDLT-G line card and NVSP-B splitter card with ISAM SW version R6.2.04ng instead of Nokia 7356 SB-REM with NDLT-G line card, NVSP-B splitter card and NRCD-C vectoring controller card.

4 Definition of harm to the network

By definition a VDSL2 line is said to cause harm to the network when it :

- Disturbs any of its neighbouring lines (typically any of the other VDSL2 lines connected to the same DSLAM) such that the service of other end users connected to any of these neighbouring lines is impaired or seriously risks to be impaired
- Leads to disproportional operational burden compared to other VDSL2 lines. A not exhaustive set of examples of disproportional operational burden is the following :
 - creating excessive support calls
 - flooding the Proximus network and / or operational systems (including the Proximus monitoring systems) with e.g. :
 - VDSL2 modem side triggered G.997.1 physical layer management requests to the DSLAM that negatively impairs the functioning of the DSLAM
 - Erroneous or inaccurate G.997.1 operational data that improperly triggers operational processes
- Causes security issues or serious security risks.



5 Proximus, CPE vendor and end user Roles and Responsibilities

5.1 Proximus Roles and Responsibilities

- Proximus will update the present specifications whenever:
 - there is a significant network change that requires an evolution of the present specifications.
 - the present specifications have been found to not be sufficiently accurate or exhaustive in order to meet the aim of the present specifications as described in section 1 and with reasonable effort amendments to the present specifications can remedy these inaccuracies or lacks of exhaustiveness.
- Proximus has / claims the right to take measures, reactively as well as proactively, regarding any VDSL2 modem connected to a VDSL2 line :
 - For which it has been established that it causes harm to the network
 - For which it is strongly suspected that it causes harm to the network
 - For which there is a high risk that it will cause harm to the network
 - That is not compliant to the present specification

These measures include, but are not limited to:

- Reducing the spectrum configured for the VDSL2 line to which said modem is connected. Often this sufficiently mitigates harm to the network and this way the end user can still enjoy a basic connectivity service.
- Remotely locking the VDSL2 network port of the VDSL2 line to which said modem is connected.
- Physically disconnecting the VDSL2 line :
 - Either at the network side
 - Or at the customer (end user) premises side
- Maintaining a blacklist of CPE. By definition any of the above 3 measures (reduce the spectrum, remotely lock the VDSL2 port, physically disconnect the VDSL2 line) shall apply whenever a blacklisted CPE is connected to the Proximus network. The blacklist entry and exit criteria will be defined at a later stage.

Note : the fact that Proximus has / claims this right does not mean that Proximus will exercise this right in an overly conservative dogmatic manner. It will be exercised in a reasonable way, balancing the benefits of all the end users that use the Proximus network, whether they use a freely chosen VDSL2 modem or a VDSL2 modem provided by Proximus or by an OLO.

- Proximus will inform the end user in case it deems it necessary to take one or several of the above-mentioned measures.
- On demand of the end user, Proximus shall reverse any of the above measures taken for a VDSL2 modem if the hardware or software root-cause that triggered the measure has been eliminated by the end user.
- Proximus regularly adapts its network by introducing new hardware and software and shall not be responsible of any service degradation following these network evolutions.
- Proximus shall NOT be responsible to make any statements of compliance to the specifications contained in this document for CPE that Proximus does not provide itself to end users or to OLO. Proximus cannot assume any such responsibility in the most explicit sense possible.



5.2 CPE vendor Roles and Responsibilities

- The CPE vendor shall be the prime responsible for making statements of compliance to the specifications contained in this document on request of end users or on request of any legal entities that sell or intend to sell said CPE onto the Belgian CPE retail market.

5.3 End user Roles and Responsibilities

- The end user shall be the sole responsible for selecting its VDSL2 CPE hardware and software compliant to the present specifications.
- The end user shall be the sole responsible for making sure that its selected VDSL2 CPE hardware and software is compliant to any evolution of the present specifications.
- The end user shall be the sole responsible for upgrading the software of its VDSL2 CPE. Such upgrades may not be mandatory but could be necessary to reach reasonable interoperability performance with recent DSLAM equipment hardware or software releases.
- The end user shall only use software approved by the VDSL2 CPE manufacturer and shall not modify it by any means.
- The end user shall install VDSL2 CPE SW patches recommended for security reasons by the VDSL2 CPE manufacturer.
- The end user shall comply with the instructions that Proximus may issue from time to time to ensure the security and correct operation of the Proximus network and of any other infrastructure used in any other manner by Proximus.
- In case Proximus deems it necessary to physically disconnect the freely chosen VDSL2 modem at the customer (end user) premises side in order to reactively or proactively prevent harm to the network, it will request the end user to :
 - disconnect the freely chosen VDSL2 modem when requested by Proximus within a lead time of 1 business day
 - grant access to the end user's premises within a maximum of 7 business days in order to verify that the freely chosen VDSL2 modem has been physically disconnected from the Proximus network

-----End of document-----